



Volvo Buses. Driving quality of life

# VOLVO B11R

## A SOLID PLATFORM FOR A PRODUCTIVE COACH





### **Reliable business results**

The Volvo B11R is the backbone of a good coach business. Whether your need is a premium coach or a trusty line-hauler, the B11R will exceed your expectations. The highly fuel-efficient Euro 6 engine will cut your operational costs, while Volvo's high quality ensures superior functionality, passenger comfort and lifecycle productivity.

⋮ *The excellent road handling and driveability make it a pleasure to drive, while your passengers will enjoy excellent stability and ride comfort. And not least benefit from Volvo's top position in reliability and safety.*

# ALL YOU NEED FOR SUCCESS

## Fuel efficiency

The new, fuel-efficient 11-litre Euro 6 engine with uncompromised power and performance combined with Volvo I-Shift and a line-up of fuel-saving services.

## True uptime

Legendary Volvo reliability, service-friendly layout and trouble-free maintenance will keep your coaches on the road. We're by your side all the way.

## For versatile applications

Premium charter or cost-efficient transit? With the Volvo B11R you will get just the coach you need. Two- or three-axle configuration combined with several power ratings allows you to optimise it for your specific operation.

## Environmental performance

At Volvo Buses we give you environmental performance with a business upside. We continuously develop technology and services to reduce the footprint of your operation even more.

## Business in partnership

Our promise is to be your best business partner, with services to maximise uptime, reduce life cycle cost, facilitate the management of your fleet and ensure high residual value.

## Driver performance

The road handling and power resources make the Volvo B11R simply great to drive. Everything in the driver's area is set for superior ergonomics. Why not add in driver training to fully exploit the potential of your coaches.

## World class safety

Safety is deep in the DNA of Volvo. Your drivers and passengers will benefit from the vehicle's predictable and consistent road behaviour and a wide range of safety features.



⋮ True uptime



# IT'S VOLVO INSIDE

**A coach belongs on the road.** Running efficiently, securing your business. We know every minute and every mile counts. That is why the Volvo B11R and our services are designed to give you maximum uptime. Proven Volvo technology and extremely durable mechanical design ensure reliability and a long service life. Add services such as Vehicle Management, Service Contracts and Driver Training and you can count on what matters: uptime 24/7.

⋮ *With Volvo quality inside you have*  
⋮ *a solid base for long-term productivity.*

## **Trouble-free maintenance**

Maintenance and reliability are crucial issues in the lifecycle productivity perspective. The B11R is designed for long service intervals and swift and simple maintenance. Many critical components are maintenance-free, such as chassis suspension, steering and prop-shafts. In addition, Volvo's multiplexed electronics system supports preventive maintenance and offers a diagnostics tool.



## **Tailored Service Contracts**

With our Service Contracts you get a service plan optimised for your business. Aspects such as operational conditions, mileage, climate, chartering or line-haul determine the solution. The result is maintenance exactly when needed, and assurance that only Genuine Volvo Parts are used – fitted by experts.



## **Vehicle Management services**

Adding our maintenance planning service helps you optimise vehicle availability and avoid unplanned stops. Through on-board telematics you know exactly how much and under what conditions your fleet is running, allowing you to adapt your maintenance and optimise your operation.



# SAVE UP TO 10% OF YOUR FUEL COST



**Fuel cost is crucial.** We can do little about the price but quite a lot about the consumption. Our new Euro 6 engines are even more efficient than their predecessors, but what matters just as much is how the vehicle is driven. That's why we continuously develop services that increase overall efficiency. With driver training, and services for fleet management it is fully possible to make fuel savings of up to 10%. Bottom line profit from day one.

- ⋮ *Save up to 10% fuel and*
- ⋮ *reduce emissions even more.*



## **Euro 6 with reduced fuel consumption**

With our new Euro 6 engine we reduce fuel consumption while maintaining power output and torque. Together with our advanced engine management system and the legendary Volvo I-Shift 12-speed gearbox you get increased efficiency while reducing the fuel cost in your business.

## **Save fuel online**

With Fleet Management you can optimise maintenance costs and reduce fuel consumption. The detailed reports allow you to trace reasons for variations in fuel consumption. When you know whether it's the vehicle, the driver or the route that causes problem, it's easy to take action.



## **More efficient with driver training**

With Driver Training you improve the skills of your drivers and save fuel, and there is huge potential here. Our expert trainers teach drivers worldwide how to drive more efficiently while at the same time providing the passengers with a pleasant ride.

⋮ For versatile applications

# BUILD YOUR COACH

With the Volvo B11R as a base you can build just the coach you need. This versatile chassis provides maximum flexibility for bodybuilding and opens up for a wide range of applications. No matter whether you aim for a premium coach, a tour and charter money-maker, a line-hauler or a transit workhorse. It's still Volvo quality and reliability all the way.

## **Capacity for passengers - and their luggage**

Your Volvo B11R can be specified to meet almost any kind of need. It's available in different lengths and its load capacity means it can cater for wide variations in the seat numbers and luggage compartment capacity. A range of power ratings, rigid or independent front suspension and two-or three-axle configuration take versatility to a new level.

## **Volvo power on tap**

Volvo engines are known for first-class driveability. The D11K Euro 6 engine is no exception and its impressive performance span is one reason why the B11R suits virtually every application. Depending on your needs you can choose from three different ratings up to 460 hp, all with massive torque across a wide rev range.



⋮ *A precision-built, rigid and durable frame with  
⋮ a flat top design provides a perfect surface to  
⋮ accommodate immense variation in bodywork.*



⋮ Safety

# THE BEST WAY TO GO

**Going by bus or coach is the safest way to travel.** Especially when you rely on Volvo. The mechanical durability creates a solid base for reliable safety, which is enhanced with a range of additional features. When it comes to preventive safety, the road behaviour of the B11R is a real asset. Consistent and predictable, it helps the driver stay in control, just like in every other Volvo.

## **Excellent handling and braking**

EBS-controlled disc brakes and the Volvo Engine Brake are well-known Volvo safety components. For top-of-the-line safety you can opt for a retarder and our Electronic Stability Program (ESP).

## **Alert and focused**

The B11R offers a solid base for a superior driver's environment. A new, easy-to-read instrument cluster, enhanced human-machine interface minimising driver distraction, adjustable steering wheel and easy-to-manoeuvre I-Shift lever are just a few examples of its features. And with I-Coaching the driver gets even more help to drive more safely and stay focused and alert.

## **Active safety**

Road handling and consistent behaviour are crucial safety factors. This is especially important in critical situations when the brakes are put to the test. High engine torque across a wide rev range in combination with the Volvo I-Shift transmission provides a unique driving feel and dependable acceleration for safer overtaking.



⋮ Driver performance

# THE DRIVER'S DREAM

**The road feel and driving experience** are truly special when in a Volvo B11R. The precise steering and smooth gear changes combined with the high engine torque, the responsiveness and the outstanding driveability make the driver's work a pleasure. Depending on application you can choose between independent and rigid front suspension, both with excellent comfort and a tight turning circle. A steerable tag axle further enhances manoeuvrability.



## **Gear up with I-Shift**

Volvo's legendary I-Shift transmission is as smooth as an automatic transmission. It combines silent shifting with fuel efficiency and lets the engine run under optimised conditions. The control software helps the driver maintain a high average speed and give the passengers a pleasant ride.



## **I-Coaching improves driver performance**

I-Coaching assists the driver in driving more safely, fuel efficiently and comfortably. It gives instant feedback on parameters such as over-revving, excessive idling, over-speed and harsh curving, helping the driver improve performance.

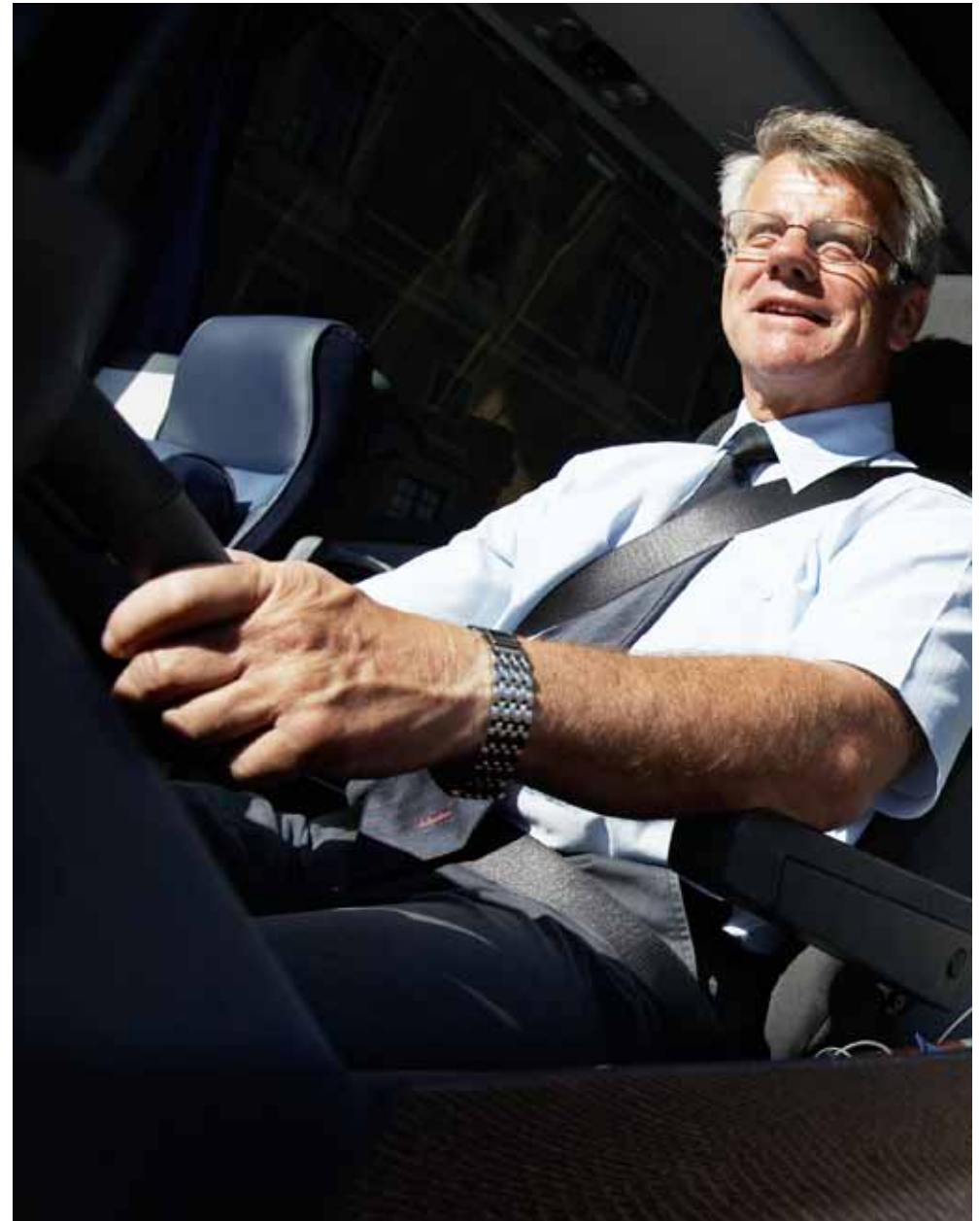

**The functional design of a Volvo B11R** naturally extends to the driver's environment. Everything is set for superior ergonomics; for example a steering wheel that adjusts in relation to the pedals, a perfectly designed I-Shift lever and the new instrument cluster designed to display only relevant information and minimise distraction.



Environmental performance

# GREEN EFFICIENCY BUILT IN



**At Volvo** we see no contradictions between environmental concern and profitability. On the contrary. That is why we lead the way when it comes to intelligent solutions that give you environmental performance and benefits with a business upside. We call it Green Efficiency, and that is what you get with every Volvo.

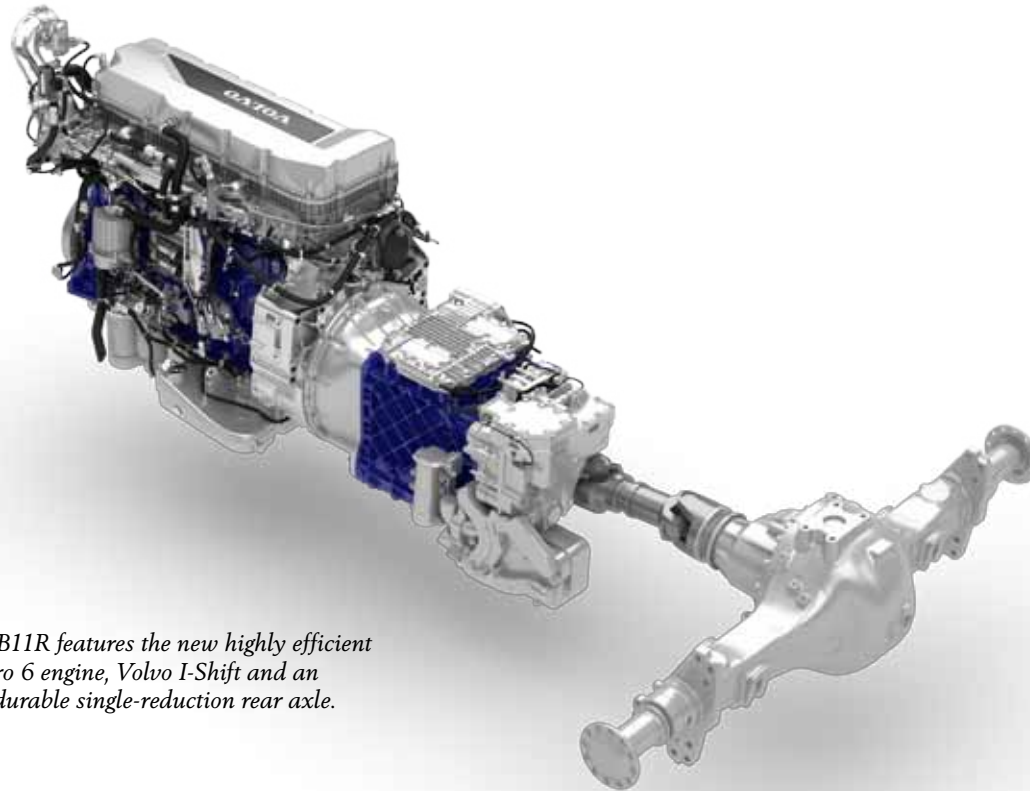

*The Volvo B11R features the new highly efficient 11-litre Euro 6 engine, Volvo I-Shift and an extremely durable single-reduction rear axle.*



## **The secret - reduced fuel consumption**

The easiest way to deliver environmental performance is to reduce fuel consumption while maintaining power output and torque. And that's exactly what we do with our new, lighter Euro 6 engines. We call it right-sizing. Together with our advanced engine management system and innovative exhaust after-treatment solution you get increased efficiency, with green benefits.

## **More efficient with driver training**

The way you drive, the way you perform. Every drop of saved fuel increases profitability. And there is huge potential. With the help of Driver Training you can increase your environmental performance still further. In addition, with our advanced on-line Fleet Management solution you can follow-up performance on a regular basis and fine-tune your operation.

Business in partnership

# IT'S THE EXTRAS THAT WILL HELP YOU SAVE MONEY

When you buy a Volvo B11R, you don't only buy a coach. You buy a business. And with our experience, knowledge and business understanding, we promise to be your best business partner. With your operation in mind, we can propose a combination of reliable services completely designed to optimise your ownership, at a well-defined cost. Ultimately helping you to maximise uptime, reduce life cycle cost and facilitate the management of your fleet. And not least, helping to secure the outstanding residual value for which Volvo Buses is so famous.



## Volvo Bus Services

With our range of services we can take part or complete responsibility for managing your vehicles and guaranteeing a trouble-free operation. Fleet Management, Vehicle Management, Service Contracts and Financing are just a few examples of services that help you stay in control of the cost and performance of your fleet.



## European Service Network

With over 1000 workshops and service centres throughout Europe, we offer personal service and support wherever you are. With our Genuine Volvo Service you can count on your coach always being serviced in the best way possible, and always with Genuine Volvo Parts to ensure the performance, reliability and safety of your coach.



## Volvo Action Service

Volvo Action Service is our assistance service, available round the clock, 365 days a year. One call and help is on the way to anyone with a fault with their Volvo bus or coach. Volvo Action Service is there to assist you with everything from repair services to financial and legal assistance, from interpreting and translation to getting your driver back home.

# FACTS AND FIGURES

## Dimensions and weights

Model	2-axle	3-axle
Overall length [m]	10.4–13.8	11.2–14.3
Transport wheelbase [m]		4.0
Approved wheelbase [m]	5.0–7.7	5.0–7.4
Overall width [m]		2.5
Frame height at rear structure [m]		1.6
Permitted GVW [kg]	19000	26500

## Powertrain

Emission standard	Euro 6
Diesel engine	Volvo D11K, 6-cylinder, in-line diesel engine with common rail injection
Output [hp] Torque [Nm]	380, 430 or 460 1800, 2050 or 2200
Transmission	Volvo I-Shift automated gear-changing system. Available with integrated retarder. Automatic transmission available for the D11K 380 [hp].

## Exhaust system

One box muffler design.

Automatic regeneration of DPF without driver involvement under normal conditions.

## Fuel tanks

Diesel [L]	220–720
AdBlue [L]	48 or 64
Transport [L]	50

## Frame

Precision built, strong, durable frame made of carbon steel.

C-profile beams with flat, bodybuilder friendly upper surface.

## Axles, suspension and steering

Front axle	Volvo Rigid or Independent Front Suspension
Rear axle	Volvo's single reduction axle with optimised ratios
Tag axle	Hydraulically steered or fixed
Suspension	Electronically controlled air suspension with kneeling function available on all variants
Power steering	Hydraulic power steering
Tyres	295/80 R22.5" 315/80 R22.5"
Rims	Steel or aluminium rims available

## Brakes

Volvo electronically controlled disc brakes (EBS), Electronic Stability Program (ESP) and Volvo Engine Brake (VEB). Brake Blending Function, Hill Start Aid and Brake Assistant.

## Driver's environment

Components such as the adjustable steering wheel, instrument cluster and the placement of the foot pedals provide the foundation for an ergonomic driver's environment. New Volvo instrument cluster with enhanced HMI.



Volvo B11R





Volvo Buses. Driving quality of life



**VOLVO**

**Volvo Bus Corporation**

Göteborg, Sweden  
[www.volvobuses.com](http://www.volvobuses.com)