

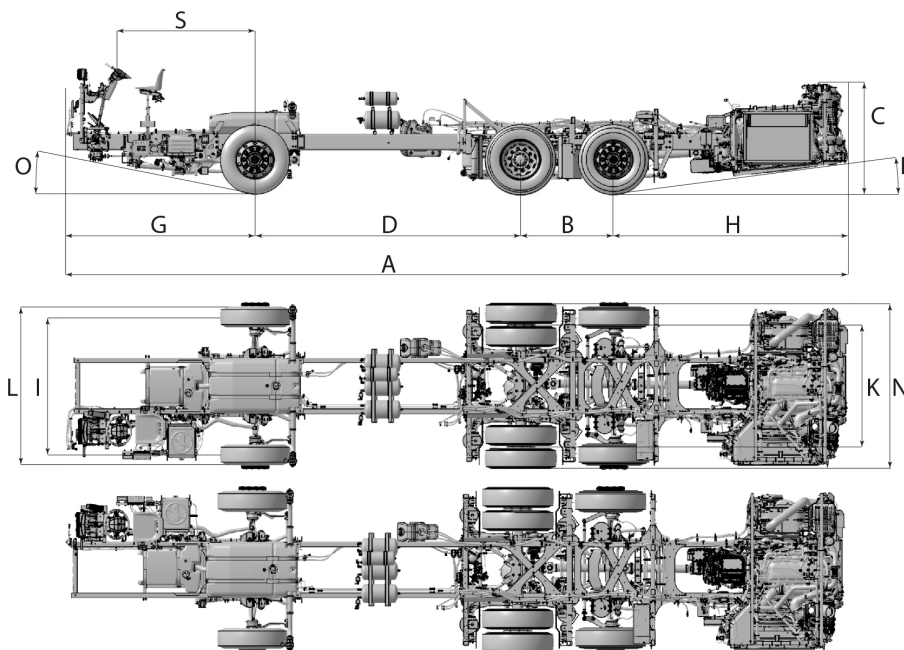

Volvo Buses. Driving quality of life

VOLVO B8R 6X2

Euro 6



Model		B8R, 6 x 2	
Overall dimensions			
A	Overall chassis length	SWP1650 (mm)	12220-14620
		SWP1820 (mm)	12390-14790
		SWP2050 (mm)	12620-15020
B	Bogie (mm)		1400
C	Frame height at rear structure (mm)*		1618
D	Transport wheelbase (mm)		4000
	Approved wheelbase (mm)		5000-7400
G	Front overhang (mm)	SWP1650 (mm)	2330
		SWP1820 (mm)	2500
		SWP2050 (mm)	2730
H	Rear overhang (mm)		3490
S	Steering wheel position (mm)	SWP1650 (mm)	1650
		SWP1820 (mm)	1820
		SWP2050 (mm)	2050
I	Track, front (mm)*		2049
K	Track, rear (mm)*		1834
L	Overall width front wheels or housing (mm)*		2500
N	Overall width rear wheels (mm)*		2500
O	Approach angle (°) (SWP1820)		8.1
P	Departure angle (°)		4.7
*) Track width, overall width and frame height are measured with tyres: and steel rims			295/80R22.5" 8.25"x22.5"

VOLVO B8R 6X2

Euro 6

Model	B8R, 6 x 2
--------------	-------------------

Weights	
Permitted front axle load (kg)	7500
Permitted drive axle load (kg)	11500
Bogie axle load (kg)	17250/19000
Permitted tag axle load (kg)	5750/7500
Permitted GVW (kg)	24750/26500

Engine	D8K
Emission standard	Euro 6
Engine system	EGR, Common rail
Displacement (dm ³)	7.7
Cylinders/arrangement	6/in-line
Engine rating	D8K280
Output (hp) (±0-4%)	280
Output ISO 1585 (kW) (±0-4%)	210
Torque ISO 1585 (Nm); at engine speed 950-1700 rpm	1071
Engine rating	D8K320
Output (hp) (±0-4%)	320
Output ISO 1585 (kW) (±0-4%)	240
Torque ISO 1585 (Nm); at engine speed 1050-1600 rpm	1224
Engine rating	D8K350
Output (hp) (±0-4%)	350
Output ISO 1585 (kW) (±0-4%)	263
Torque ISO 1585 (Nm); at engine speed 1200-1600 rpm	1428

Fuel tanks	
Diesel (L)	220, 300, 2x150, 310, 360, 375, 410, 480, 600, 720
Transport (L)	50
AdBlue (L)	30, 48, 64

Transmission and axles	
Gearboxes	Volvo I-Shift AT2412F ZF 6AP1200C (280 hp) ZF 6AP1400C (320 & 350 hp) Voith D864.6 (320 hp)
Front axle	Volvo RFS
Rear axle	Volvo RS1228C
Tag axle	Hydraulic steered/Fixed
Differential lock	Optional

Suspension and steering	
Air bellows, front	2
Air bellows, drive	4
Air bellows, tag	2
Kneeling	Optional
Max wheel angle	52° with 295/80R22.5 tyres
Power steering	Hydraulic power steering
Steering wheel position	LHD/RHD

VOLVO B8R 6X2

Euro 6

Important information

For variants concerning wheelbase, steering wheel diameter and permitted front axle load, see Type approval according to ECE R79 and ECE R13.

Exhaust system

- One box muffler design
- Diesel Oxidation Catalyst (DOC)
- Diesel Particulate Filter (DPF)
- Selective Catalytic Reduction (SCR)
- Ammonia Slip Catalyst (ASC)
- Automatic regeneration of DPF without driver involvement under normal conditions
- On Board Diagnostic (OBD) for emissions, according to step C of emission regulations
- Engine certified hydrotreated vegetable oil (HVO, standard EN 15940)
- Biodiesel available for D8K320

Cooling system

- Pivotal radiator to ease access for maintenance
- No coolant filter
- Coolant level warning in instrument cluster
- Higher allowed coolant temperature for better cooling performance and lower fuel consumption

Tyres and rims

Steel or aluminium rims available

Rims	Tyres
8.25" x 22.5"	295/80 R22.5"
9.00" x 22.5"	315/80 R22.5"
Spare wheel	Optional

Air and brake system

- Collision Warning with Emergency Brake (CW-EB)
- Volvo disc brakes
- Electronic Stability Control (ESC)
- Electronic Braking System (EBS 5)
- Anti-lock Braking System (ABS)
- Acceleration Slip Regulation (ASR)
- Brake blending
- Dual retarder control
- Drag torque control
- Hill Start Aid
- Brake temperature warning
- Poor brake performance warning
- Door brake
- Brake assistant
- Lining wear sensing and analysis
- Automatic calibration after brake pad change
- Compressed air system, easily filled from external circuit

Cut-in pressure 9.5 bar

Cut-out pressure 10.8 bar

Driver's station

Cluster and controls transit mounted. Also available with Volvo dashboard:

- Dashboard moves with the steering column in height and tilt
- Available in EBSF and VDV version with multistalk for wiper and direction indicator on left side of the steering wheel
- Instrument cluster
 - speedometer
 - rev counter
 - 6.5" display
 - fuel gauge
 - coolant temperature
 - brakes
 - turbo and oil pressure
 - indicators
 - warning lamps
- Tachograph
- Data logging
- Volvo Alcolock
- External temperature meter
- Fuel economy meter
- Radio/phone switches in steering wheel
- Engine controls in engine compartment to enable engine operation from the rear of vehicle
- Lane Keeping Support
- Volvo Dynamic Steering (VDS)
- Adaptive Cruise Control

VOLVO

Volvo Bus Corporation

volvobuses.com

VOLVO B8R 6X2

Euro 6

Electrical system

- Volvo I-Start system
 - dual battery system that separates batteries into two circuits
 - optimised start batteries to increase engine start capability
 - optimised consumer batteries for longer lifetime
- Automatic shut off of main switch at low voltage level
- Load balanced alternators
- Regenerative charge control to increase fuel efficiency

Number of batteries

Start batteries	2 x 12 V
Consumer batteries	2 x 12 V

Battery capacity

Consumer batteries	105 Ah
--------------------	--------

VOLVO

Volvo Bus Corporation
volvobuses.com